



Cisco VOIP Phones 7945 and 7965 Quick Reference Guide



Cisco 7945

About the Phone

Cisco 7965



The Key Difference

What is the difference between the Cisco 7945 and 7965? The Cisco 7965 has more line keys, everything else is the same. The 7965 has six line keys and can add up to 24 additional line keys (using a key module). The 7945 has two line keys.

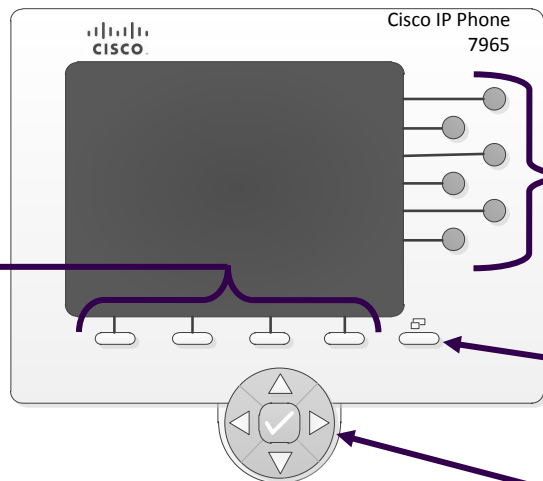

Line Keys

One line key is always the primary phone number. CS&T can program the other keys to be **speed dials** (regular or busy notification) or **line appearances**.

Status Indicator Lights

- Green, Steady—Active Call
- Green, Blinking—Held Call
- Amber, Steady—One way intercom call or logged into Hunt group
- Amber, Blinking—Incoming call or reverting call
- Red, Steady —remote line in use (shared line)

Display button

When lit, the phone is in sleep mode.
Press the button to wake up the screen.

Softkeys

These keys display different menu options as you use the phone.

Navigation buttons

The arrows let you toggle in all four directions.
You press the **Select button** (square button with a check mark) to choose a menu option.

Line appearance is when another phone number rings on your phone. It will be a **device line appearance (other people's phone numbers) or a **phantom** line appearance (number that isn't primary on any phone —e.g. department's main phone number).

Basic Settings

Button Icon	Button Feature	Button Icon	Button Feature
	directories button <ul style="list-style-type: none"> • Missed calls • Received calls • Placed calls • UCF Directory 		settings (con't) <ul style="list-style-type: none"> • Change Ringtones <ul style="list-style-type: none"> • settings > User Preferences > Rings • Choose phone line or default ring setting. • Choose a ring tone to play a sample of it. • Press Select button and then Save soft key to set the ring tone, or press Cancel.
	messages button Automatically dials voicemail.		VOLUME button <ul style="list-style-type: none"> • Change the volume of the ringer <ul style="list-style-type: none"> • Take handset off the hook • Press VOLUME key to adjust ringer level • Press Save soft key • Change the volume during a call <ul style="list-style-type: none"> • Press VOLUME key to adjust ringer level
	settings <ul style="list-style-type: none"> • Change Wallpaper <ul style="list-style-type: none"> • settings > User Preferences > Wallpaper • Highlight the image, press Select button. • Press Save soft key, then press Exit. • Change Screen Brightness <ul style="list-style-type: none"> • settings > User Preferences> Brightness • Adjust using the navigation button (up and down). 		

Using the Phone

Dialing Plan for UCF Numbers

Main Campus: 2-xxxx or 3-xxxx (2 or 3 and the last four digits)

Lake Nona: 6-xxxx (6 and the last four digits)

Rosen College: 3-8xxx (3, 8 and the last three digits)

Brevard Regional Campus: 50-xxxx (50 and the last four digits)

UCF Downtown or Florida Interactive Entertainment Academy: 5-xxxx (5 and the last four digits)

Dialing plan for Non-UCF Numbers

Local: 9 plus the ten digit number; 9-407-xxx-xxxx or 9-321-xxx-xxxx

Long Distance (if added to plan): 9-1-Area Code-xxx-xxxx



Forwarding Your Calls

- Press the **CFwdALL** softkey.
- Enter the **five digit UCF phone number**.

The phone will display “Forwarded to XXXXX”.

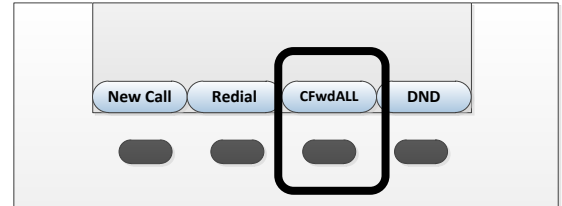

Removing Call Forwarding

- Press the **CFwdALL** to remove call forwarding.



Transferring Received Calls

- Press the **Transfer** softkey.
- Enter the **phone number** (use dialing plan format above).
- (Optional) Announce the caller when line is picked up.
- Press the **Transfer** softkey.

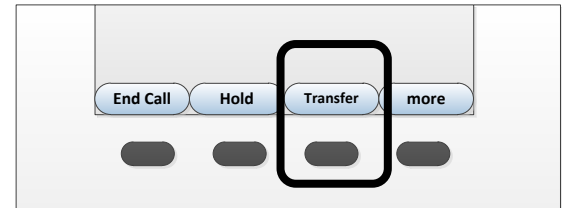

Stop the transfer

- Press **End Call**. Your caller will be on hold.
- To try another transfer, press **New Call** softkey.
- To return to the caller, press the **Resume** softkey.

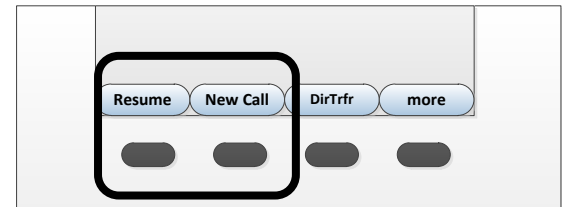

Conference Calls

- While on line with first caller, press **Confrm** softkey.
 - If not displayed on the softkeys, press **more** first.
- Enter phone number.
- When call to connects, press **Confrm** softkey again.
- You can repeat these steps until 8 total are in the call.

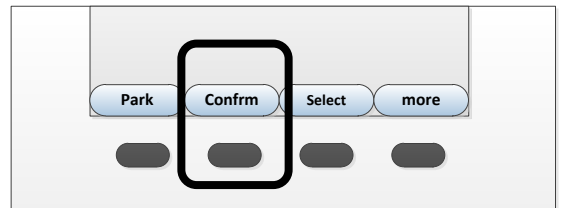

Do Not Disturb (DND)

- Press **DND** softkey to turn on or off the ringer on the phone.

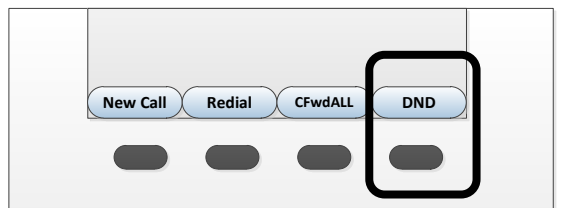

Visit the [Telecom Resources](http://www.cst.ucf.edu) page on www.cst.ucf.edu for more advanced guides and videos

